

1. Machine Room Above Electric Traction Lifts



General Specifications									
Rated load		kg	320	450	630	800	1000	1250	1600
Rated speed		m/s	1 m/s and 1.6 m/s						
Car internal dimensions			Check the design dimensions						
Type of doors			2 or 3 panels side-opening doors and 2 or 4 panels centre-opening doors. Articulated doors						
Clear door opening		mm	700 – 800 – 900 – 1000 – 1100 - ...						
Car entrances	1 m/s		1 entrance, 2 entrances at 180°, 2 entrances at 90° (for loads up to 800 kg)						
	1.6 m/s		1 entrance, 2 entrances at 180° (no option for two entrances at 90°)						
Maximum stops / entrances			32						
Maximum car travel	1 m/s	m	60						
	1.6 m/s		90						
Type of hoist machine	1 m/s		2 speed (2V) or variable speed (VWF) Traction drive unit consisting of gearbox with a special steel horizontal worm gear and a bronze wormwheel, three-phase asynchronous motor and electromagnetic brake						
	1.6 m/s		Variable speed (VWF) Traction drive unit consisting of gearbox with a special steel vertical worm gear and a bronze wormwheel, three-phase asynchronous motor and electromagnetic brake						
Hoist machine model	1 m/s		O-130		O-170			MF-82	MF-94
	1.6 m/s		O-170			MF-82	MF-94		
Motor power	1 m/s	kW (2V)	4	5.5	7.3	8.8	11.7	15.4	18.4
		kW (V3F)	4	5.5	7.3	11	11	15.4	18.4
	1.6 m/s	kW	7.3	11	11	13.2	16.2	20.6	25
Number of ropes	1 m/s		4 ø 9	4 ø 11	4 ø 11	3 ø 11	4 ø 11	4 ø 13	5 ø 13
	1.6 m/s		4 ø 11	5 ø 11	5 ø 11	5 ø 13	5 ø 13	6 ø 13	8 ø 13
Car guiderails	1 m/s		T-70A	T-70A	T-82A	T-90A	T-90A	T-90A	T-125B
	1.6 m/s		T-90B	T-90B	T-90B	T-90B	T-125B	T-125B	T-127B
Counterweight guiderails	1 m/s		T50A	T50A	T50A	T65A	T70A	T70A	T90A
	1.6 m/s		T50A	T50A	T65A	T70A	T90B	T90B	T90B
Counterweight guiderails (with safety gear)	1 m/s		T-70A	T-70A	T-70A	T-90A	T-90A	T-90A	T-125B
	1.6 m/s		T-70A	T-90B	T-90B	T-90B	T-90B	T-125B	T-125B
Roping	1 m/s		1:1	1:1	1:1	2:1	2:1	2:1	2:1
	1.6 m/s		1:1	1:1	1:1	1:1	1:1	1:1	1:1

Design dimensions for side-opening doors, centre-opening doors, with counterweight at the rear (1 entrance)

Persons	Rated Load	Doors Size			Car internal			Recommended Shaft Size				Headroom height		Pit depth					
					Width	Depth	Height	Width		Depth		1m/s	1.6m/s	1m/s	1.6m/s				
	kg	Type	(mm) Clear opening	(mm) HPL	(mm) AC	(mm) FC	(mm) HC	1m/s (mm)	1.6m/s (mm)	1m/s (mm)	1.6m/s (mm)	(mm)	(mm)						
	Q							AH	AH	FH	FH	HUP	Pit depth						
4	320	TT	700	2000	1000	875	2100	1375	1400	1400	1425	3600	3700	1100	1250				
					825	1100		1325	1350	1625	1650								
		CC	700	2000	1000	875	2100	1525	1550	1325	1350								
					825	1100		1525	1550	1550	1575								
6	450	TT	800	2000	900	1350	2100	1500	1525	1875	1900	3600	3700	1100	1250				
					1000	1200		1500	1525	1725	1750								
					1000	1250		1500	1525	1775	1800								
					1000	1200		1625	1650	1725	1750								
					1000	1250		1625	1650	1775	1800								
					1000	1250		1725	1750	1800	1825								
		CC	800	2000	900	1350	2100	1725	1750	1800	1825								
					1000	1200		1725	1750	1650	1675								
					1000	1250		1725	1750	1700	1725								
					1000	1200		1925	1950	1650	1675								
					1000	1250		1925	1950	1700	1725								
					1000	1250													
8	630	TT	800	2000	1000	1550	2100	1500	1525	2075	2100	3600	3700	1100	1250				
					1100	1400		1525	1550	1925	1950								
					1000	1550		1625	1650	2075	2100								
					1100	1400		1650	1675	1925	1950								
					1000	1550		1725	1750	2000	2025								
					1100	1400		1725	1750	1850	1875								
		CC	800	2000	900	1350	2100	1925	1950	2000	2025								
					1000	1550		1925	1950	1850	1875								
					1100	1400		1925	1950	1850	1875								
					1000	1550													
					1100	1400													
					1100	1400													
10	800	TT	800	2000	1350	1400	2100	1800	1825	2000	2025	3600	3700	1150	1250				
					1100	1600		1600	1625	2200	2225								
					1350	1400		1800	1825	2000	2025								
					1100	1600		1700	1725	2200	2225								
					1350	1400		1825	1850	1925	1925								
					1100	1600		1825	1850	2125	2150								
		CC	800	2000	900	1350	2100	1950	1975	1925	1950								
					1000	1550		1950	1975	2125	2150								
					1100	1600		1950	1975	2125	2150								
					1350	1400													
					1100	1600													
					1100	1600													
13	1000	TT	900	2000	1400	1600	2100	1850	1875	2200	2225	3600	3700	1150	1250				
					1300	1700		1750	1775	2300	2325								
					1100	2100		1700	1725	2700	2725								
					1400	1600		1850	1875	2200	2225								
					1300	1700		1850	1875	2300	2325								
					1100	2100		1850	1875	2700	2725								
		CC	900	2000	1400	1600	2100	1950	1975	2150	2175								
					1300	1700		1950	1975	2250	2275								
					1100	2100		1950	1975	2650	2675								
					1400	1600		2150	2175	2150	2175								
					1300	1700		2150	2175	2250	2275								
					1100	2100		2150	2175	2650	2675								
16	1250	TT	1100	2100	1350	2100	2200	2000	2050	2775	2800	3800	3900	1300	1400				
		CC						2350	2400	2700	2750								

Note: DOORS RESTING
 · Landing doors resting completely inside the shaft.

Design dimensions for side-opening doors, centre-opening doors, with side counterweight (1 and 2 entrances at 180°)

Persons	Rated Load	Doors Size			Car internal			Recommended Shaft Size					Headroom height		Pit depth		
					Width	Depth	Height	Width		Depth		Depth 2 entrances	1m/s	1.6m/s	1m/s	1.6m/s	
		Type	(mm) Clear opening	(mm) HPL	(mm) AC	(mm) FC	(mm) HC	1m/s (mm)	1.6m/s (mm)	1m/s (mm)	1.6m/s (mm)	1 and 1.6m/s (mm)	(mm)	(mm)	1m/s (mm)	1.6m/s (mm)	
		kg Q						AH	AH	FH	FH	FH	HUP		Pit depth		
4	320	TT	700	2000	1000	875	2100	1550	-	1250	-	1435	3600	3700	1100	1250	
					825	1100		1375	1400	1475	1500	1660					
		CC	700	2000	1000	875	2100	1600	1625	1175	1200	1290					
					825	1100		1550	1575	1400	1425	1515					
6	450	TT	800	2000	900	1350	2100	1525	1550	1725	1800	1910	3600	3700	1100	1250	
					1000	1200		1550	1575	1575	1600	1760					
					1000	1250		1550	1575	1625	1650	1810					
					1000	1200		1650	1675	1575	1600	1760					
					1000	1250		1650	1675	1625	1650	1810					
					1000	1250		1750	1775	1650	1675	1765					
		CC	800	2000	900	1350	2100	1750	1775	1650	1675	1765	1815				
					1000	1200		1750	1775	1500	1525	1615					
					1000	1250		1750	1775	1550	1575	1665					
					1000	1200		1950	1975	1500	1525	1615					
					1000	1250		1950	1975	1550	1575	1665					
					1000	1250		1950	1975	1550	1575	1665					
8	630	TT	800	2000	1000	1550	2100	1575	1600	1925	1950	2110	3600	3700	1100	1250	
					1100	1400		1675	1700	1775	1800	1960					
					1000	1550		1675	1700	1925	1950	2110					
					1100	1400		1675	1700	1775	1800	1960					
					1000	1550		1750	1775	1850	1875	1965					
					1100	1400		1750	1775	1700	1725	1815					
		CC	800	2000	1000	1550	2100	1950	1975	1850	1875	1965	2015				
					1100	1400		1950	1975	1850	1875	1965					
					1000	1550		1950	1975	1700	1725	1815					
					1100	1400		1950	1975	1700	1725	1815					
					1000	1550		2075	2150	1775	1800	1960					
					1100	1600		2075	2150	1775	1800	1960					
10	800	TT	800	2000	1350	1400	2100	2075	2150	1775	1800	1960	3600	3700	1150	1250	
					1100	1600		1825	1900	1975	2000	2160					
					1350	1400		2075	2150	1775	1800	1960					
					1100	1600		1825	1900	1975	2000	2160					
					1350	1400		2075	2150	1700	1725	1815					
					1100	1600		1825	1900	1900	1925	2015					
		CC	800	2000	1350	1400	2100	2075	2150	1700	1725	1815	2015				
					1100	1600		2075	2150	1700	1725	1815					
					1350	1400		2075	2150	1700	1725	1815					
					1100	1600		1950	2050	1900	1925	2015					
					1350	1400		2125	2200	1975	2000	2160					
					1100	1600		2025	2100	2075	2100	2260					
13	1000	TT	900	2000	1400	1600	2100	1800	1875	2475	2500	2660	3600	3700	1150	1250	
					1300	1700		2125	2200	1975	2000	2160					
					1100	2100		2025	2100	2075	2100	2260					
					1400	1600		1850	1925	2475	2500	2660					
					1300	1700		2150	2225	1900	1925	2015					
					1100	2100		2050	2100	2000	2025	2115					
		CC	900	2000	1400	1600	2100	2000	2050	2400	2425	2515	2515				
					1300	1700		2175	2200	1900	1925	2015					
					1100	2100		2175	2200	2000	2025	2115					
					1400	1600		2175	2200	2000	2025	2115					
					1300	1700		2175	2200	2400	2425	2515					
					1100	2100		2175	2200	2400	2425	2515					
16	1250	TT	1100	2100	1350	2100	2200	2150	2200	2500	2525	2660	3800	3900	1300	1400	
		CC			2350	2400		2400	2450	2515							
21	1600	TT	1100	2100	1400	2400	2200	2200	2250	2800	2825	2960	3800	3900	1300	1400	
					1300	2350		2350									
		CC	1100	2100	1400	2400	2200	2500	2525	2700	2725	2815	2815				
					1300	2750		2775									

Note: DOORS RESTING
 · Landing doors resting completely inside the shaft.

Shaft side view

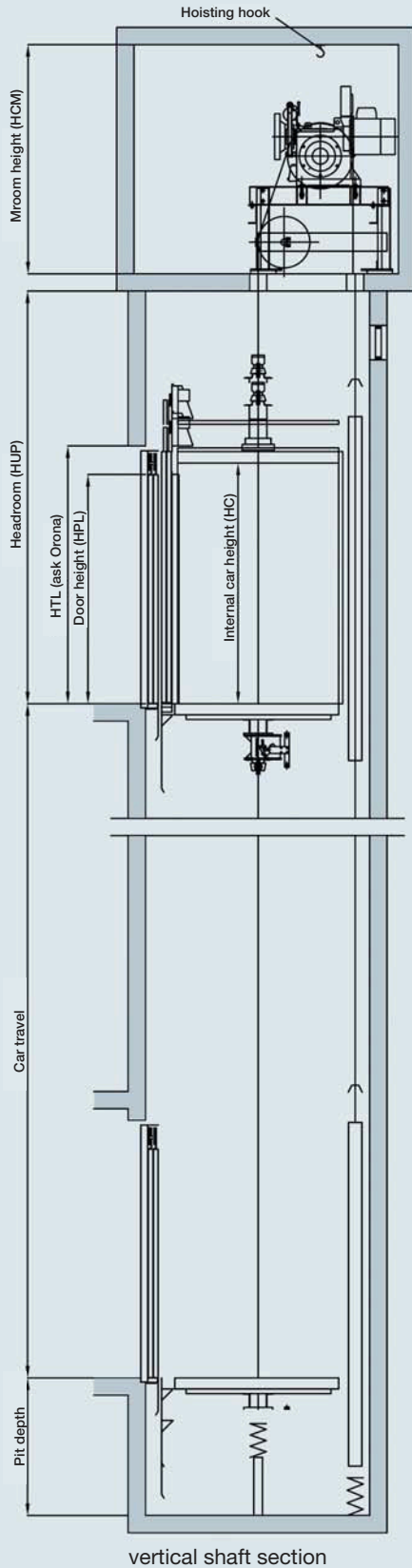

Plan view of shaft

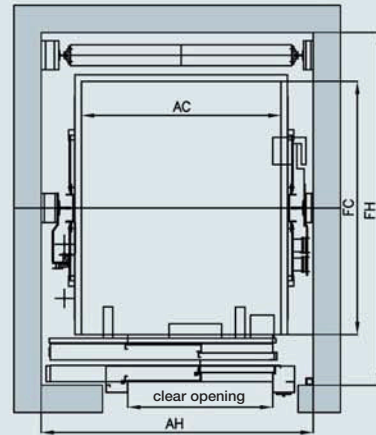

Horizontal section, TT doors,
1 entrance, counterweight at rear

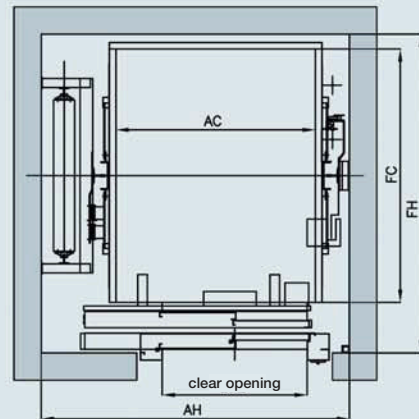

Horizontal section, TT doors,
1 entrance, counterweight at side

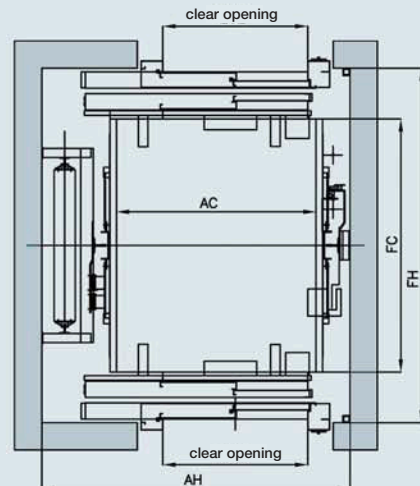

Horizontal section, TT doors,
2 entrances at 180°, counterweight at side